

Nr.	Omschrijving	Artikelnummer	Nr.	Omschrijving	Artikelnummer
1	SET POTEN COMPL.	XSPC90034000			
2	SCHROEVEN/MOERENSET TBV FRAME	XSPC90238000			
3	BLOKKEERHENDEL	XSPC90120000			
4	SET SPATLAPPEN	XSPC90132000			
5	WATERSTOP COMPL.	XSPC84025000			
6	KUNSTSTOF DOP TBV POOT	XSPC90090000			
7	SET MONTAGEPLATEN TBV BRUGSTEUN	XSPC90207000			
8	SET BRUGSTEUNEN	XSPC90209000			
9	SET LINIALEN	XSPC90223000			
10	BESCHERMBEUGEL LASER	XSPC90217-10			
11	SCHROEVEN/MOERENSET TBV BRUG	XSPC90239000			
12	KABELBOOM	XSPC90084000			
13	THERMISCHE VEILIGHEID	XSPC90081000			
14	SPANNINGSAANDUIDING ROOD/GROEN	XSPC90082000			
15	SCHAKELAAR	XSPC90080000			
16	ELECTRO-UNIT	XSPC90079000			
17	AANSLUITDOOS COMPL.	XSPC90203-F0			
18	OPBOUWSTEKKER COMPL. 230V	XSPC90242000			
19	ELEK WATERPOMP P-3 P-3500	XWPE030000			
20	WATERSLANG	XSPC07071R00			
21	HOEKPROFIEL LINKS INCL. BLOKKEERHENDEL	XSPC90121000			
22	GLIJLATTEN RVC TBV BRUG P-3520	XSPC90218-20			
23	SET VOORAANSLAGEN	XSPC90213000			
24	BOVENTAFEL COMPL. P-3520	XSPC90216-20			
25	VARIABELE MATERIAALAANSLAG COMPL.	XSPC90235000			
26	HANDWIEL COMPL. (ZONDER KABEL) P-3520	XNB90166-200			
27	STALEN KABEL TBV HANDWIEL P-3520	XSPC90251-20			
28	BRUG COMPL. P-3520	XSPC90200-20			
29	KABELANTENNE	XSPC90251F00			
30	WATERBAK P-3520	XSPC90135-20			
31	HANDGREEP COMPL.	XSPC90119000			
32	BLOKKEERHENDEL COMPL. TBV POOT	XSPC90039000			
33	WIELSTEL COMPL.	XNB90102R000			
34	GEREEDSCHAPSET COMPL.	XSPC03032000			
35	ALUMINIUM FRAME COMPLEET	XSPC90232-20			
36	DICHTING MONTAGEPLAAT MOTOR	XSPC90059000			
37	COMPLEET CONTROLEBORD 230V/50HZ	XSPC90234/S			
38	HANDWIEL	XSPC902500			
39	KABEL CLIP MET SCHROEVEN	XSPC670180			
40	COMPLETE KABEL 36 SCHAKELS MET SCHROEVEN	XSPC90271150			
	SNOER INCLUSIEF CEE CONTRA STEKER	XSPC90159000			

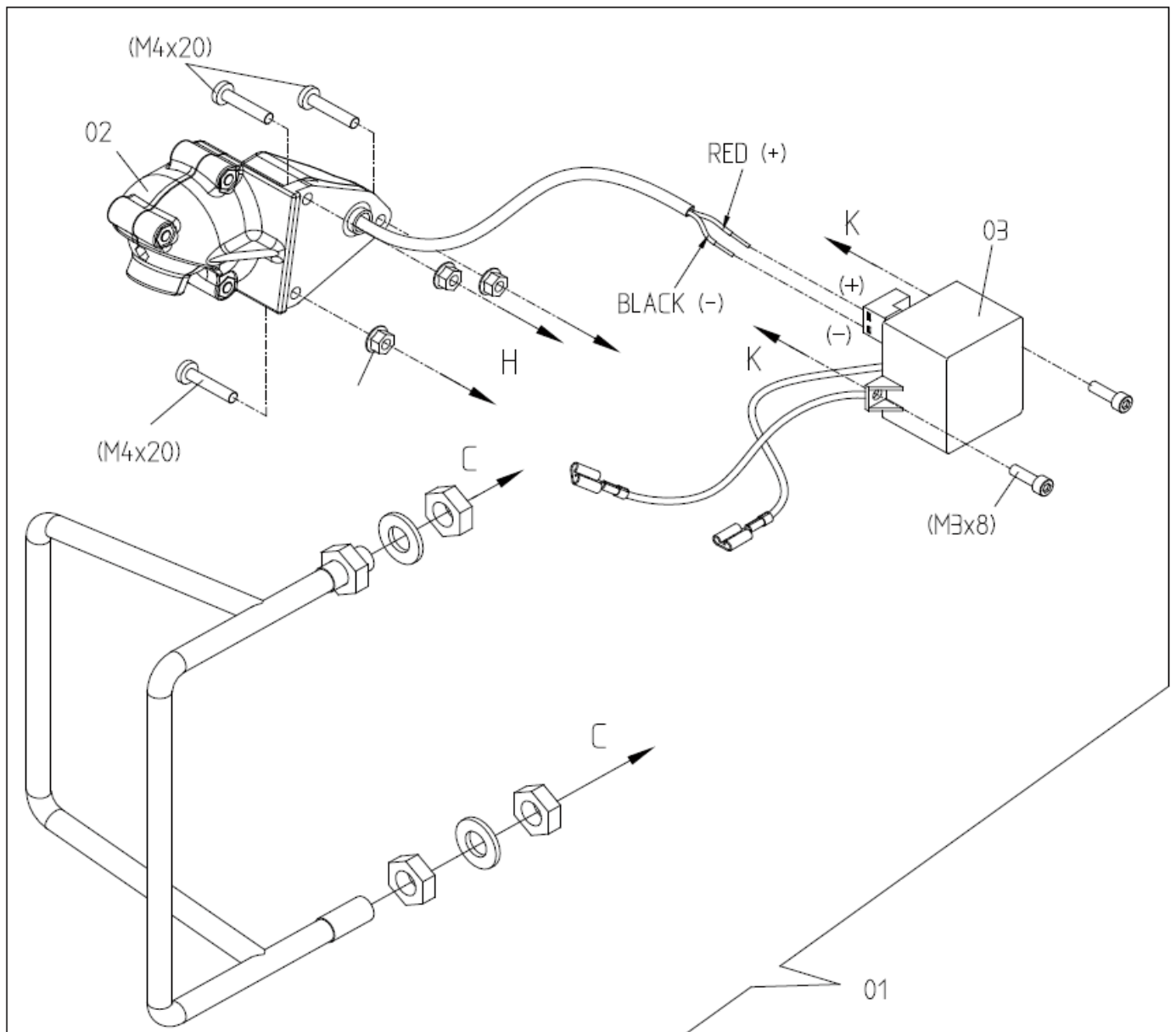

Nr.	Omschrijving	Artikelnummer	Nr.	Omschrijving	Artikelnummer
1	SCHROEVEN/MOERENSET TBV MOTOR	XSPC90067000			
2	VENTILATOR + KAP	XSPC90014000			
3	HANDLEIDING	XSPC90554000			
4	VELD COMPL. 230V	XSPC90097000			
5	LAGER/RINGENSET TBV MOTOR	XSPC09504200			
6	CONDENSATOR 40MF.	XSPC90083-10			
7	HANDGREEPBEUGEL COMPL.	XSPC90206000			
8	KUNSTSTOF HANDGREEP	XSPC03055000			
9	SPROEIVORK COMPL.	XSPC90016000			
10	SET MONTAGERINGEN TBV ZAAGKAP	XSPC90031000			
11	FLENZENSET COMPL.	XSPC90005000			
12	PLAAT ZAAGKAP COMPL. Ø350MM	XSPC90022000			
13	ZAAGKAP COMPL. Ø350MM	XSPC90229000			
14	WATERKRAAN COMPL.	XSPC90153000			
15	SET SPATLAPPEN	XSPC90132000			
16	SET FRICTIERINGEN	XSPC90042000			
17	VEER TBV HOOGTE-INSTELLING	XSPC90044000			
18	LAGERSET TBV ZAAGWAGEN	XSPC90237000			
19	ZAAGWAGEN COMPL.	XSPC90230000			
20	SET MONTAGEPLAATJES	XSPC90020000			
21	SET LINIALEN	XSPC90223000			
22	MONTAGEPLAAT MOTOR	XSPC90205000			
23	VOEDINGSKABEL NAAR MOTOR	XSPC90165000			
24	ANKER COMPL.	XSPC90047000			
25	AFDEKKAP TBV VELD COMPL.	XSPC90056000			
26	MOTOR + OPHANGING COMPL.	XSPC90233-10			
27	MOTOR COMPL. 230V	XSPC90231000			
28	WATERSLANG	XSPC07071T00			
29	DICHTING MONTAGEPLAAT MOTOR	XSPC90059000			

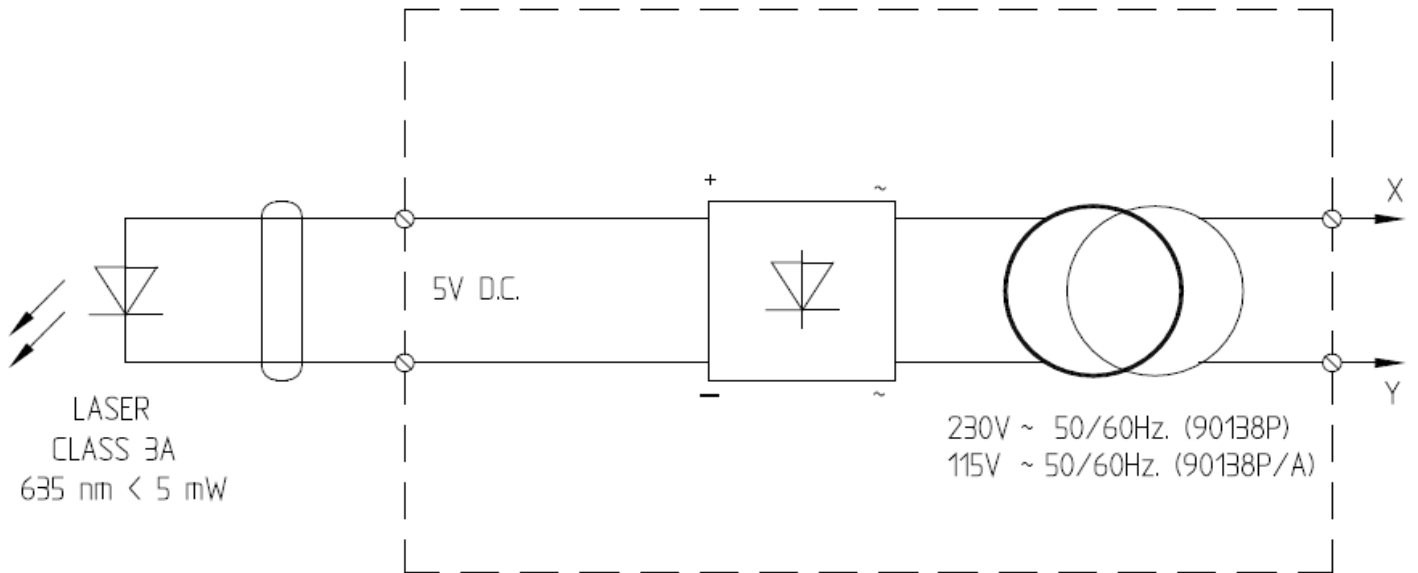

Nr.	Omschrijving	Artikelnummer	Nr.	Omschrijving	Artikelnummer
1	LASER COMPL.	XNB901690000			
2	LASER UNIT	XSPC90137000			
3	LASER VOEDING	XSPC90138P00			